

Loader Mfg. _____

Nelson Long
W. R. Long Inc.
nlong@wrlonginc.com
www.wrlonginc.com
252-823-4570 (phone)
252-823-4577 (fax)

Loader Model Number _____

Person Filling Out This Form _____

Phone Number _____

Selector Valve Kit Measurements

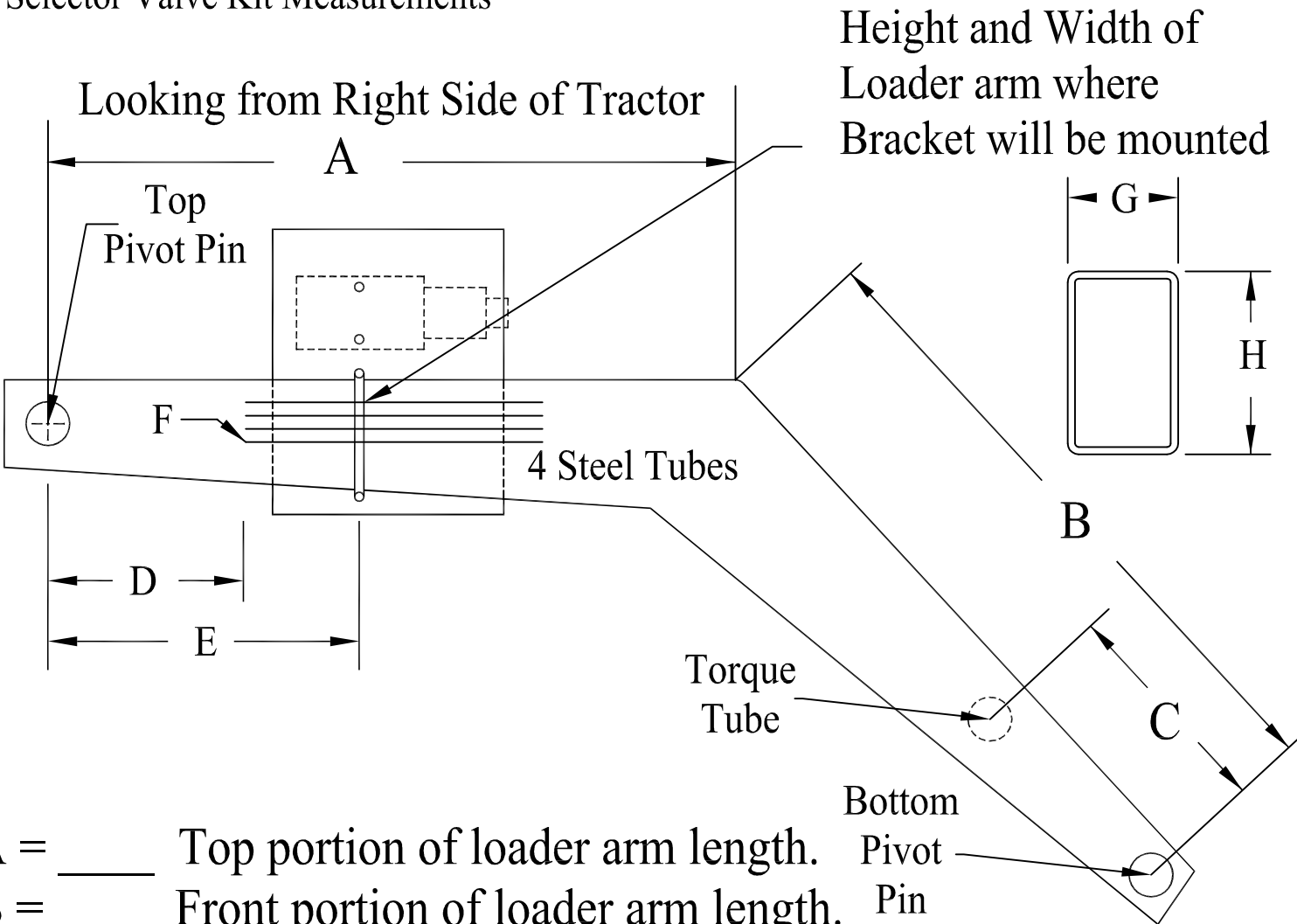

- A = _____ Top portion of loader arm length.
- B = _____ Front portion of loader arm length.
- A + B = _____ Total length from top pivot pin to bottom pivot pin.
- C = _____ Distance from Torque Tube to bottom pivot pin.
- D = _____ Distance from top pivot pin to Steel Tubes.
- E = _____ Clear location for $\frac{5}{16}$ u-bolt that mounts valve bracket.
- F = Type Fitting on Hose that connects to Steel Tube.

[Male or Female x Type x Size]

- G = _____ Width of loader arm where bracket will be mounted.
- H = _____ Height of loader arm where bracket will be mounted.